

SERIOUS INCIDENT

Aircraft Type and Registration:	Boeing 747-4H6, 9M-MPL	
No & Type of Engines:	4 Pratt & Whitney PW4056-3	
Year of Manufacture:	1998	
Date & Time (UTC):	17 August 2012 at 2320 hrs	
Location:	On approach to Runway 09R at London Heathrow Airport	
Type of Flight:	Commercial Air Transport (Passenger)	
Persons on Board:	Crew - 22	Passengers - 340
Injuries:	Crew - None	Passengers - None
Nature of Damage:	Electrical failures, hard landing and component failure to No 2 engine	
Commander's Licence:	ATPL	
Commander's Age:	40 years	
Commander's Flying Experience:	10,753 hours (of which 393 were on type) Last 90 days - 80 hours Last 28 days - 11 hours	
Information Source:	AAIB Field Investigation	

Synopsis

Significant vibration was noted on the No 2 engine during departure from London Heathrow Airport. The engine subsequently failed and was shut down by the crew who elected to jettison fuel and return to Heathrow Airport. During the approach for a planned autoland, all three autopilots disengaged, the cockpit displays and lights flickered and a series of fault messages were displayed. The resulting electrical failures culminated in a loss of power to one of the electrical AC buses, and many of the systems powered by this bus were lost or degraded. The commander continued the approach, manually flying the aircraft to a safe landing.

The investigation determined the flickering cockpit displays and lights resulted from a series of failures within the aircraft electrical system, primarily caused by a latent mechanical failure in a Bus Tie Breaker. The effect of this latent failure only became apparent when the aircraft electrical system automatically reconfigured for the planned autoland. One Safety Recommendation has been made.

History of the flight

9M-MPL was operating a commercial air transport flight from London Heathrow Airport to Kuala Lumpur International Airport with 4 flight crew, 18 cabin crew and 340 passengers. Following normal pre-flight preparation the aircraft took off at 2129 hrs and departed towards the north-east.

As the aircraft climbed through FL150 the crew felt the aircraft vibrate. All cockpit indications were normal but the engine No 2 vibration indicator was indicating 2.3, slightly higher than the 0.9 indicating on the other three engines. The commander disconnected the autopilot, checked the flying controls then re-engaged the autopilot. The vibration increased as the aircraft climbed through FL170 and the pilots noticed that fuel flow on engine No 2 was fluctuating at around 0.3 tonnes per hour compared with approximately 5 tonnes per hour for the other engines. The commander selected idle thrust on engine No 2, which reduced the vibration, but the pilots noticed that the engine oil pressure had exceeded the limit. They then heard a bang and the ENG FAIL EICAS¹ message was displayed in respect of engine No 2. The crew shut down the engine in accordance with the 'ENGINE LIMIT OR SURGE OR STALL' checklist, asked ATC for permission to level off at FL190 and stated that the aircraft would be returning to Heathrow Airport. The aircraft was sent to LOGAN² to hold while it jettisoned fuel.

After jettisoning fuel, which took approximately 45 min, 9M-MPL began its initial approach towards Runway 09R at London Heathrow Airport with the left autopilot in command. The crew briefed for an autoland because the aircraft was heavy, it was night and one engine had been shut down. Apart from the fact that the aircraft was operating on three engines, all other systems were operating normally. The aircraft intercepted the localiser while descending through 3,200 ft amsl and the crew engaged the two remaining autopilots in preparation for the autoland. Shortly after the aircraft levelled at 3,000 feet amsl, the master warning was triggered, the three autopilots disengaged, all the displays and cockpit lights began to flicker and a large number of failure messages appeared on the EICAS displays. The commander began to fly the aircraft manually and approximately thirty seconds later, as the aircraft intercepted the glideslope, the autothrust disengaged.

The pilots decided that, with the runway in sight, the safest course of action was to continue the approach rather than manage the failures. The commander was concerned that all the displays might fail and it would therefore be better to land as soon as possible. He attempted to re-engage autothrust without success but he did not try to re-engage an autopilot. All of the screens flickered "one at a time and continuously" until touchdown. The standby instruments were unaffected.

As the aircraft approached the runway, the commander was expecting the radio altimeter automatic callout of heights above touchdown to begin at 100 ft but the only automatic call he heard was at 20 ft. He therefore did not have sufficient warning to flare the aircraft into the correct landing attitude prior to touchdown. The co-pilot stated subsequently that the radio altimeter indication and "rising runway"³ indication were missing from his Primary Flight Display (PFD) during the landing. While taxiing to stand after landing the displays stopped flickering and, after shutdown, the commander reported a "hard landing" in the aircraft technical log.

Footnote

¹ EICAS: Engine Information and Crew Alerting System.

² LOGAN: an ATC reporting point in the North Sea at N51 44.9, E001 36.7.

³ A virtual representation of the runway on the PFD designed to give the pilot an impression of the aircraft's closure to the runway.

Comments by the commander

The commander commented later that it had been unnecessary to declare an emergency because he had sufficient information available to maintain a safe flight path. He stated that had he been forced to fly the aircraft solely on standby instruments due to a complete failure of his primary flight display he would have declared an emergency.

Flight recorders

The aircraft was fitted with a two-hour solid-state CVR and a solid-state DFDR. In addition, a solid-state Quick Access Recorder, which recorded essentially the same parameter set as the DFDR, had been fitted to support the operator's flight data monitoring programme. Upon replay, the CVR was found to have recorded over the incident flight and subsequent landing, and the information that it contained did not assist the investigation.

The DFDR data showed that the departure from London Heathrow at 2129 hrs was uneventful and all engine parameters appeared normal. The recordings showed that takeoff gross weight was 377,000 kg and the aircraft was carrying 149,000 kg of fuel. A ground track of the entire flight derived from the DFDR recording is shown in Figure 1.

Engine failure

At 2140 hrs, as the aircraft was climbing through FL130, the No 2 engine oil temperature started to increase markedly. At the same time there was a step increase recorded in the level of broadband vibration and the vibration levels associated with the N₂ stage of the same engine; no change in engine thrust was evident with all engines indicating an engine pressure ratio (EPR) of about 1.4. The status of the left autopilot, which had been the only one engaged, changed to disengaged but was re-engaged 26 seconds later.

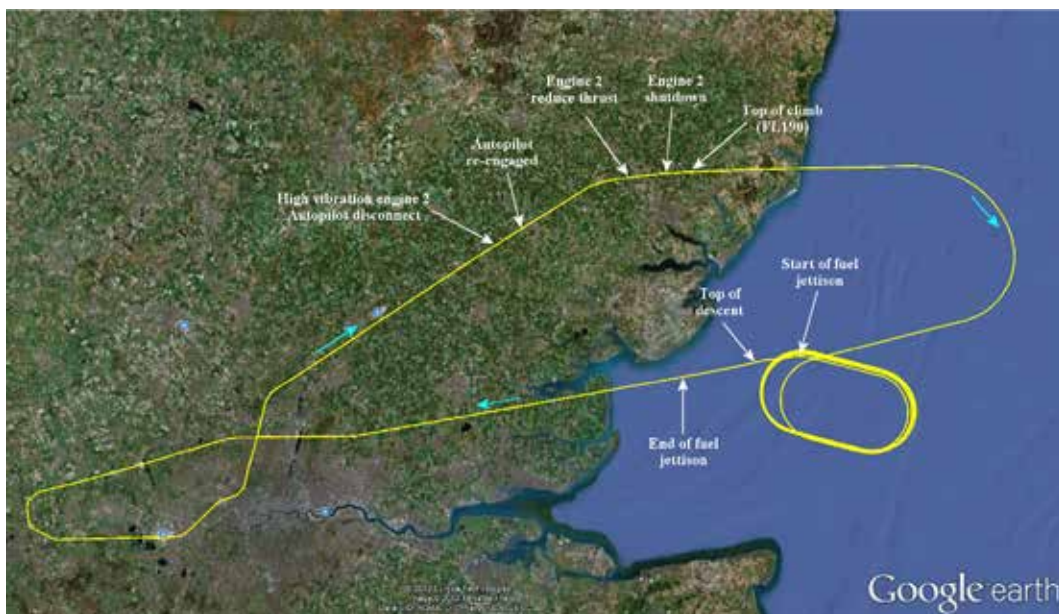

Figure 1
9M-MPL Ground radar track

As the aircraft levelled at FL190, the pilots reduced thrust on engine No 2, initially to an EPR of 1.17 and then to idle before shutting it down. The DFDR recorded engine No 2 peak values of 159.5°C for oil temperature, 4.06 units for broadband vibration and 2.14 units for the vibration associated with N₂.

A DFDR parameter associated with each of the four AC electrical busses indicated whether the bus was powered. Prior to and after the shutdown of engine No 2, the DFDR data indicated that all four AC busses remained powered. No parameters were available to show the state of APU operation.

Fuel jettison

Between 2201 hrs and 2243 hrs, whilst in a holding pattern at FL190 over the North Sea, the crew jettisoned about 75,000 kg of fuel to reduce the aircraft's gross weight to approximately 285,000 kg. As the fuel jettison was concluding, the crew started a descent towards Heathrow.

Approach

The initial approach for the ILS on Runway 09R was uneventful. Flap 1, 5 and 10 were selected in succession and the localiser was captured at 2301:43 hrs whilst descending in a left turn through 3,160 ft amsl.

At 2301:56 hrs, at 3,080 ft amsl on the extended centreline and just before rolling wings level, all three autopilots were engaged. Eleven seconds later, having levelled at about 3,000 ft amsl, AC Bus 2 indicated a momentary⁴ loss of power together with, in the subsequent second, a master warning and the disengagement of all three autopilots. All autopilots remained disengaged for the remainder of the flight.

At 2302:36 hrs, the aircraft intercepted the glideslope and started a final descent. The crew lowered the landing gear and selected Flap 20; autothrust disconnected about 24 seconds later. Flap 25 was selected at about 2,420 ft amsl and Flap 30 at 1,840 ft amsl with the aircraft stable on the ILS and with an airspeed of about 164 kt.

At 426 ft agl, 35 seconds before touchdown, AC Bus 2 lost power and remained in that state until after the landing. Following the loss of AC Bus 2, some other parameters showed anomalies: hydraulic system 2 indicated low pressure and the recorded positions of the left inner and left outer trailing edge flaps changed instantaneously to zero. Seventeen seconds later the lower yaw damper also reported a fault. The approach ground track is shown in Figure 2.

Footnote

⁴ The status of an AC electrical bus is sampled once every four seconds. Only one sample of an 'unpowered' status was recorded so the maximum time that the bus could have been unpowered was just less than eight seconds.

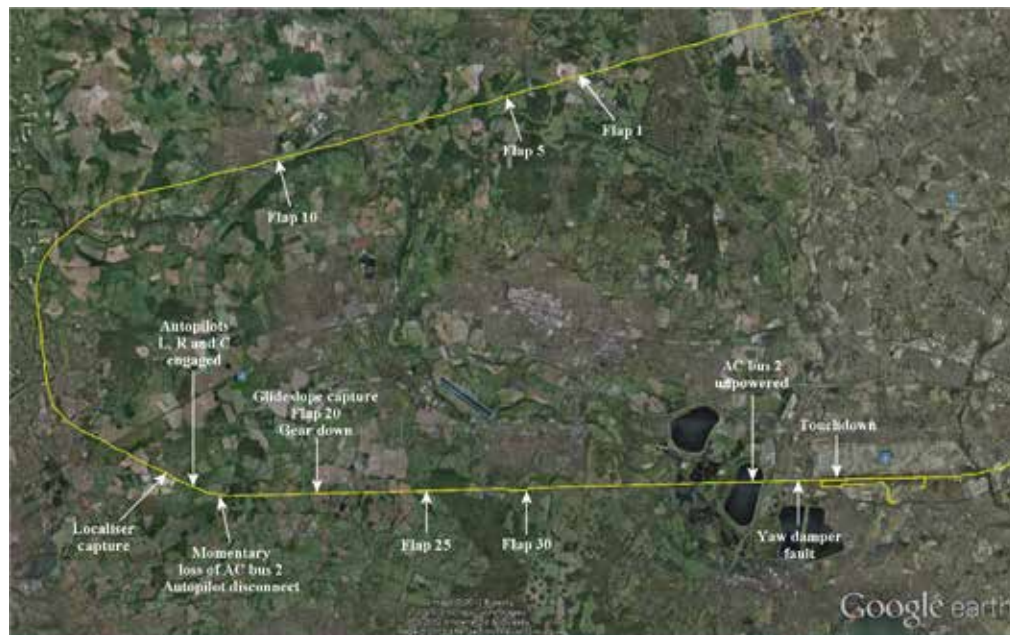

Figure 2

9M-MPL Ground radar track

Landing

Aft movement of the control column and the start of the aircraft pitching up indicate that the flare commenced between 34 ft agl and 12 ft agl. Touchdown occurred at 2306:03 hrs at 155 kt, 1.5° right wing down and with a drift angle of +2.4°. A peak normal acceleration of 1.41g and a peak lateral acceleration of 0.167g were recorded at the point of ground contact. From the change in successive samples of radio altitude, the rate of descent at touchdown was between 6 ft/sec and 8 ft/sec. Gross weight at touchdown was 282,700 kg.

The remainder of the rollout was uneventful; thrust reversers were deployed on engine Nos 1, 3, and 4 only. The aircraft vacated Runway 09R, taxied onto Stand 431 and stopped. After the aircraft had come to a halt, AC Bus 2 status returned to the powered state at 2314:34 hrs; the DFDR stopped recording at 2314:59 hrs.

Preliminary examination of the aircraft

General

The aircraft was examined the morning after the incident. There was no visible external damage to the No 2 engine, fan or fan casing, but particles of metallic debris were found in the engine tail pipe. There was also considerable metallic debris on the master magnetic chip detector (MCD) and the No 3 bearing MCD. The aircraft had also sustained damage to the keel beam during the hard landing.

Centralised Maintenance Computer data

The aircraft *Centralised Maintenance Computer* (CMC) Present Legs Faults (PLF) report for the incident flight contained a number of faults relating to the No 2 engine failure and subsequent shutdown, between 2141 hrs and 2144 hrs.

In addition, the PLF contained a series of faults associated with the aircraft electrical system and faults relating to aircraft systems which had been lost or degraded when AC Bus 2 became permanently unpowered at 2305 hrs. These are shown in the following table.

Time	CMC Faults	Nature of Fault
2302	BUS CONTROL UNIT/ FCC-C FAIL	INTERMITTENT
	BUS CONTROL UNIT/ FCC-L FAIL	INTERMITTENT
	ELEC BUS ISLN 4 - BUS TIE BREAKER 4 TRIPPED 'DIFFERENCE CURRENT' (GCU-4)	HARD
	AC BUS 2 NOT POWERED	INTERMITTENT
	FIRST OFFICERS AC BUS NOT POWERED	INTERMITTENT
	FO XFR BUS – FO TRANSFER RELAY FAIL (BCU)	INTERMITTENT
	AC BUS 2>IRU-R INTERFACE FAIL	INTERMITTENT
	WINDOW HEAT-1R AC POWER INPUT FAIL	INTERMITTENT
2303	WINDSHEAR SYS - WXR-R TRANSCEIVER FAIL	INTERMITTENT
	WINDSHEAR PRED - WXR PREDICTIVE WINDSHEAR SYSTEM FAIL	INTERMITTENT
2305	ELEC BUS ISLN 1 – ADVISORY, BUS TIE BREAKER-1 TRIP 'DIFFERENCE CURRENT' (GCU-1)	HARD
	WXR WAVEGUIDE SWITCH FAIL	INTERMITTENT
2306	DATALINK SYS - SCID-1 CARD FAIL OR ACARS/ACARS-R > SCID-1 CARD BUS FAIL	INTERMITTENT
	ACARS MU - SCID-1 CARD FAIL OR ACARS/ACARS-R > SCID-1 CARD BUS FAIL	INTERMITTENT

The PLF also contained some non-specific status messages relating to the window heat, APU bleed isolation, weather radar system, fuel override pumps and the flight director bar bias.

The CMC Fault History Summary Report, which records details of faults from the previous 60 sectors, also showed an 'ELEC BUS ISLSN 4 - BUS TIE BREAKER 4 TRIPPED 'DIFFERENCE CURRENT' (GCU-4)' fault on 14 June 2012.

Engine exceedance reports

The Aircraft Centralised Maintenance System (ACMS) generated a number of Engine Exceedance Reports between 2144:05 hrs and 2144:31 hrs, which were printed after the aircraft landed. The exceedance reports were triggered by high oil temperatures on the No 2 engine. Peak values of 165°C for oil temperature and 2.9 units for No 2 engine vibration were recorded.

Aircraft Electrical Power Generation System (EPGS)

Electrical power

There are four electrical networks on the B747-400. A separate 'Standby Power' network provides power to the most critical aircraft systems when the primary source is lost. A simplified schematic of the electrical system architecture is shown in Figure 3.

Each network has 115 V Alternating Current (AC) and 28 V Direct Current (DC) portions. Four Integrated Drive Generators (IDG), one mounted on each engine gear box, normally provide power for the electrical system. The IDGs convert mechanical power from the engines into an AC electrical supply (3-phase, 115 V, at a frequency of 400 Hz). The 115 V AC power from the IDGs is provided to four main AC buses⁵ (AC Bus 1, 2, 3 and 4), through Generator Circuit Breakers (GCB).

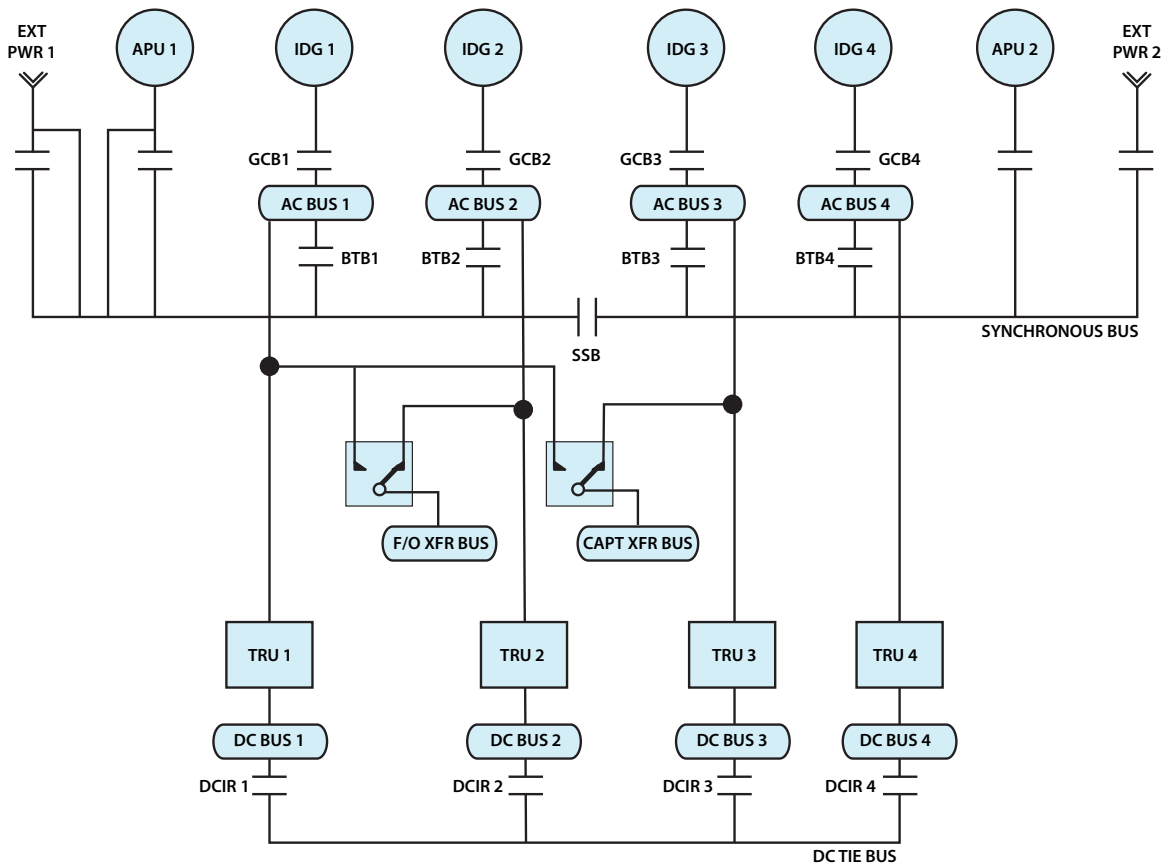

*Adapted from Copyright material,
with permission of The Boeing Company*

Figure 3

Simplified schematic of B747-400 Electrical System Architecture

Footnote

⁵ A bus or busbar is an electrical conductor with a high current-carrying capacity from which multiple circuits can be fed.

The electrical system can also be supplied by external power from a ground power unit (GPU) when parked, or by the Auxiliary Power Unit (APU) generator. In this case AC power is provided to the main AC buses via the synchronous bus and the Bus Tie Breakers (BTB).

The main AC buses supply other AC buses, which distribute power to the aircraft's AC systems and Transformer Rectifier Units (TRUs), which convert the AC supply into 28 V DC. AC Bus 1 supplies TRU 1 which provides power to DC Bus 1, and so on. DC Isolation Relays (DCIR) tie the DC buses to a common DC Tie Bus.

System configuration

The aircraft electrical system can operate in several split or parallel configurations. The IDGs are automatically synchronized so they can be connected to a common synchronous bus ("sync bus") to distribute load and provide backup power for all AC buses.

In normal flight operations all four electrical channels operate in parallel (Figure 4). In this configuration each AC bus is 'tied' to the sync bus by a closed BTB. If the Split System Breaker (SSB) on the sync bus is also closed, then the aircraft electrical loads will be shared equally by all four IDGs. This is known as parallel operation. If the SSB is open, the electrical system can be operated as two separate parallel systems (left and right).

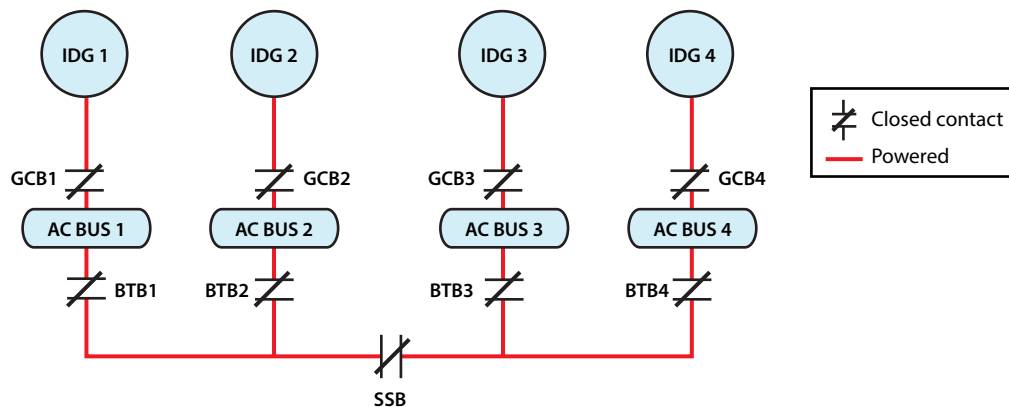

*Adapted from Copyright material,
with permission of The Boeing Company*

Figure 4

EPGS configuration in normal parallel operation

When the system operates as a fully split system, all BTBs are open (Figure 5). Each main AC bus is powered only by its own IDG, via the GCB. The AC buses are said to be isolated from the sync bus.

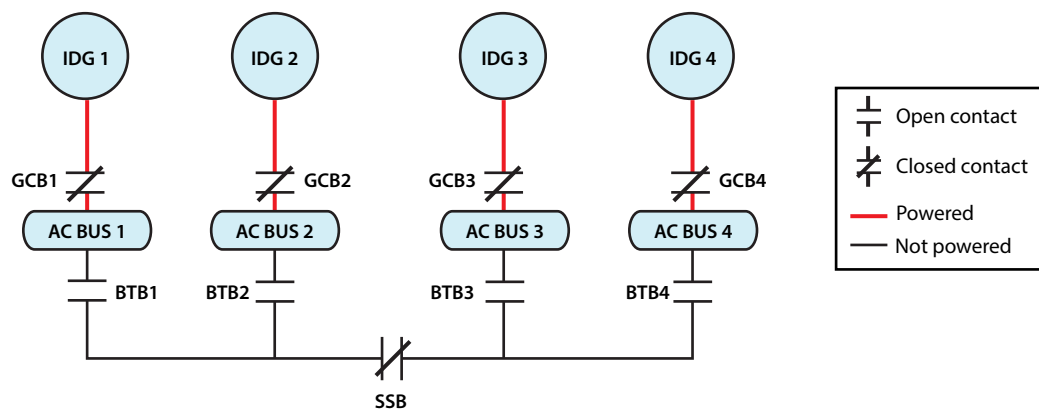

*Adapted from Copyright material,
with permission of The Boeing Company*

Figure 5

EPGS configuration in split operation

Electrical load shedding

The IDGs and APU generator each have a maximum output rating of 90 kVA (kilovolt-amperes). Each generator is individually capable of supplying the aircraft's electrical requirements. If the electrical demand on an IDG exceeds its output capability, progressive automatic load shedding of non-essential loads takes place. Load shedding will occur if the load on an IDG exceeds 83.8 kVA for 4 minutes, or exceeds 105.2 kVA for 5 seconds.

EGPS control

The EGPS is designed for automatic operation to minimise flight crew workload. Two Bus Control Units (BCU 1 and 2) and four Generator Control Units (GCU 1 - 4) control, protect and regulate the EPGS in automatic and manual modes. Each GCU provides system protection and control for its IDG and operates in conjunction with the BCUs. The GCUs will also isolate IDG faults and open the appropriate GCB to protect the EGPS.

The electrical power control panel on the flight deck overhead panel annunciates the status of the electrical system and also allows for manual operation of the electrical system. A synoptic display showing the status of the electrical power system can also be displayed on the lower EICAS screen.

Circuit breakers

Circuit breakers, or contactors, are used extensively throughout the B747-400 electrical system and include the BTBs, GCBs and SSB. These identical components, Part Number B-430Z, are also used on the B747-8 aircraft. The contactors have three main contacts: T1 L1 for Phase A current; T2/L2 for Phase B; and T3/L3 for Phase C. There are also 26 pairs of auxiliary contacts (1/2, 3/451/52) which fulfil a variety of functions within the electrical system (Figure 6).

The contactor can be in one of two states, 'closed' or 'tripped' (open). In normal parallel operation of the electrical system, the main contacts of the BTBs, GCBs and SSB are closed. They are said to be 'normally closed'. When the main contacts are closed, half of the auxiliary contacts are 'normally open' and the other half are 'normally closed', depending on their specific function within the electrical system. All of the main and auxiliary contacts are mechanically attached to a single armature, which moves in response to the magnetic field created by energising an electrical coil within the contactor. When the contactor is energised the armature moves and magnetic forces hold it in the closed position. When the contactor is de-energised, the armature returns to the tripped position and is held in position by spring force.

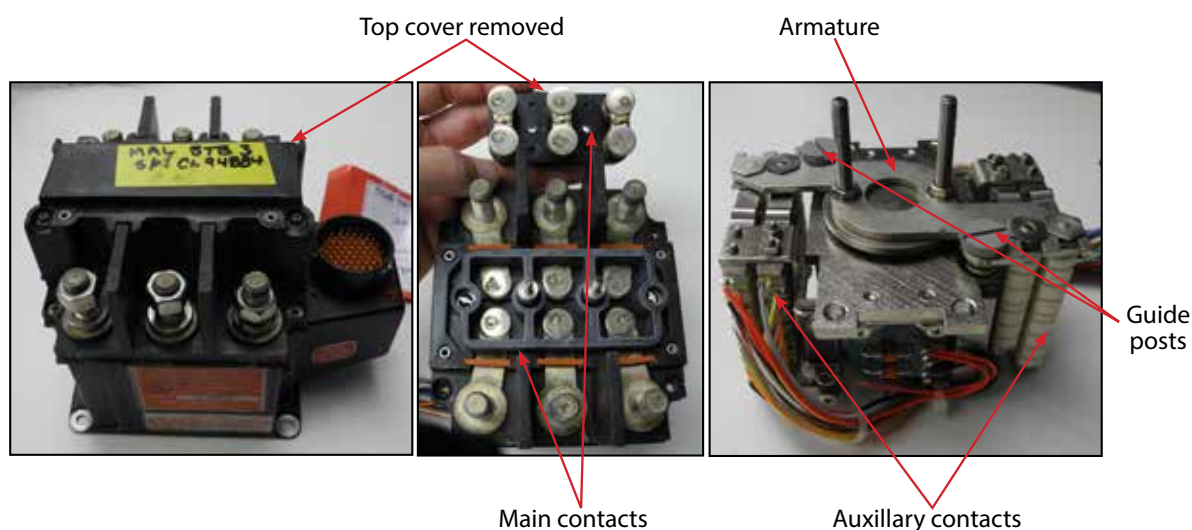

Figure 6
B430Z Contactor

Auxiliary contacts 51/52 on the BTBs, GCBs and SSB are used for the Difference Current Protection circuit. They are 'normally open'; that is, when the main contacts are closed, this set of auxiliary contacts will be open, and vice versa. BTB auxiliary contacts 15 /16 provide status information to BCU 1 and auxiliary contacts 31/32 provide status to BCU 2.

Difference Current Protection

Difference Current Protection (DCP) is one of the electrical system protections provided by the GCU. It provides a means to detect and correct imbalances in electrical load division between the IDGs when they are operating in parallel. A dedicated sensing loop uses current transformers⁶ (CTs) to measure the Phase C current flow from each IDG and compares it with the average current flow from all the paralleled IDGs.

Footnote

⁶ A current transformer is a device used to measure current when the current in a circuit is too high to apply measuring instruments directly in the circuit. It produces a reduced current accurately proportional to the current in the primary circuit which can then be measured. The primary circuit is largely unaffected by the insertion of the CT.

The output current from each IDG flows through a Generator Control Current Transformer (GCCT) which produces a current signal proportional in magnitude and phase angle to Phase C of the IDG output current. The CT signal current has two possible paths: out of the CT and through a GCU sensing circuit, and back to the CT; or out of the CT and around an equalizing loop. The actual current signal flow path may be a combination of both and depends on the IDG loading while operating in parallel.

If all the IDG load currents are equal and perfectly balanced, the CT signals will be equal in magnitude and phase angle and will flow entirely through the equalizing loop and the CT. No CT signal current will flow through the GCU sensing circuit, indicating that the system is in perfect balance.

When imbalances are present, a signal will flow around the equalizing loop that is equal to the average output of the un-shorted CTs connected in the loop. If a particular CT generates a signal different from the average CT output, the portion representing the difference from average will flow through the associated GCU sensing circuit. The current flow in the GCU sensing circuit indicates the direction and magnitude by which that IDG load differs from the average load current of the paralleled generators.

If the current output of an IDG differs from this average by more than 37.5 +/- 2.5 amps, corrective signals will be generated to maintain stable system operation. These include tripping the BTB on the affected channel, to isolate the respective AC Bus and therefore protect the IDG from a load imbalance. As the difference from average increases, the time between the fault occurrence and the protective BTB trip decreases, according to an inverse time delay logic.

When a generator is removed from parallel operation, such as when engine No 2 was shut down, the GCB main contacts open to isolate the IDG from the rest of the channels. The total system load is redistributed among the remaining IDGs operating in parallel. With the GCB main contacts open, the GCB difference current auxiliary contacts 51/52 close to provide a short circuit across the GCU sensing circuit; any GCCT signal current will then flow around the equalising loop. The short circuit prevents any current flow from the equalising loop or the CT from reaching the GCU sensing circuit, effectively disabling difference current protection for that channel.

A similar short circuit will occur through the difference current auxiliary contacts when any GCB or BTB is tripped open. Thus difference current sensing and protection remains active only on the generators operating in parallel. Therefore in theory, a DCP BTB trip can only occur for an IDG which is operating in parallel with other IDGs.

The DCP design allows for a maximum of 1 ohm contact resistance in the auxiliary contacts of the BTBs and GCBs. A resistance of more than 1 ohm will give the GCU false current measurements on the GCU sensing circuit, and may cause the BTB on that channel to trip.

Autoland isolation

When an aircraft performs a triple channel autoland⁷, the aircraft electrical system is divided into three separate power sources, in order to provide the three Flight Control Computers (FCCs) with three independent AC and DC power sources. This process is known as autoland isolation and is managed by the BCUs. In normal operations the right FCC is powered from IDG 2; the left from IDG 1 and the centre from IDG 3. IDG 4 provides backup power during the autoland operation if any other IDG is inoperative.

When the approach is armed, the three Flight Control Computers (FCCs) send an autoland isolation request to BCU 1. BCU 1 determines the number of IDGs and TRUs that are operating and the status of the BTBs, GCBs, SSB and DCIRs. Based on this information BCU 1 decides how to divide the electrical system and directs the GCUs to operate the BTBs and DCIRs to isolate the electrical buses to the FCCs.

There are five possible system configurations determined by which, if any, IDG or TRU is inoperative. Each IDG and TRU is considered as an individual power generator (PG) by the autoland logic. If an IDG and TRU on the same channel are inoperative, they are considered as a single PG. If more than one PG is inoperative, BCU 1 ignores the autoland request as three independent power supplies cannot be assured.

BCU 2 monitors BCU 1 to see that power is isolated for each autopilot channel and then sends a bus isolated signal to the FCCs to confirm that the buses are isolated. If the bus isolation does not occur within 4 seconds of the autoland request, the request is cancelled and the autopilot goes to a 'NO LAND 3'⁸ condition.

If an IDG or TRU fails while in autoland configuration, BCU 1 reconfigures the system to re-power the lost AC and DC buses. If more than one IDG or TRU becomes inoperative during autoland, the confirmation signal from BCU 2 to the FCCs is removed and the autoland is cancelled. If this occurs at an altitude above 200 ft the BTBs and DCIRs return to their original position before autoland and a 'BUS CONTROL UNIT / FCC FAIL' EICAS message is generated for the affected FCCs.

As IDG 2 was offline during the approach on the incident flight, in order to achieve three separate power sources BCU 1 would have commanded BTBs 1 and 3 to trip to isolate their respective channels. BTB 4 and BTB 2 would have remained closed so that IDG 4 supplied power to AC Bus 2 via the sync bus. Figure 7 shows the configuration of 9M-MPL's electrical system at the commencement of the autoland.

Footnote

⁷ A fully automatic landing using three independent autopilot systems.

⁸ 'NO LAND 3' is an EICAS message which reflects that a triple channel autoland cannot be performed.

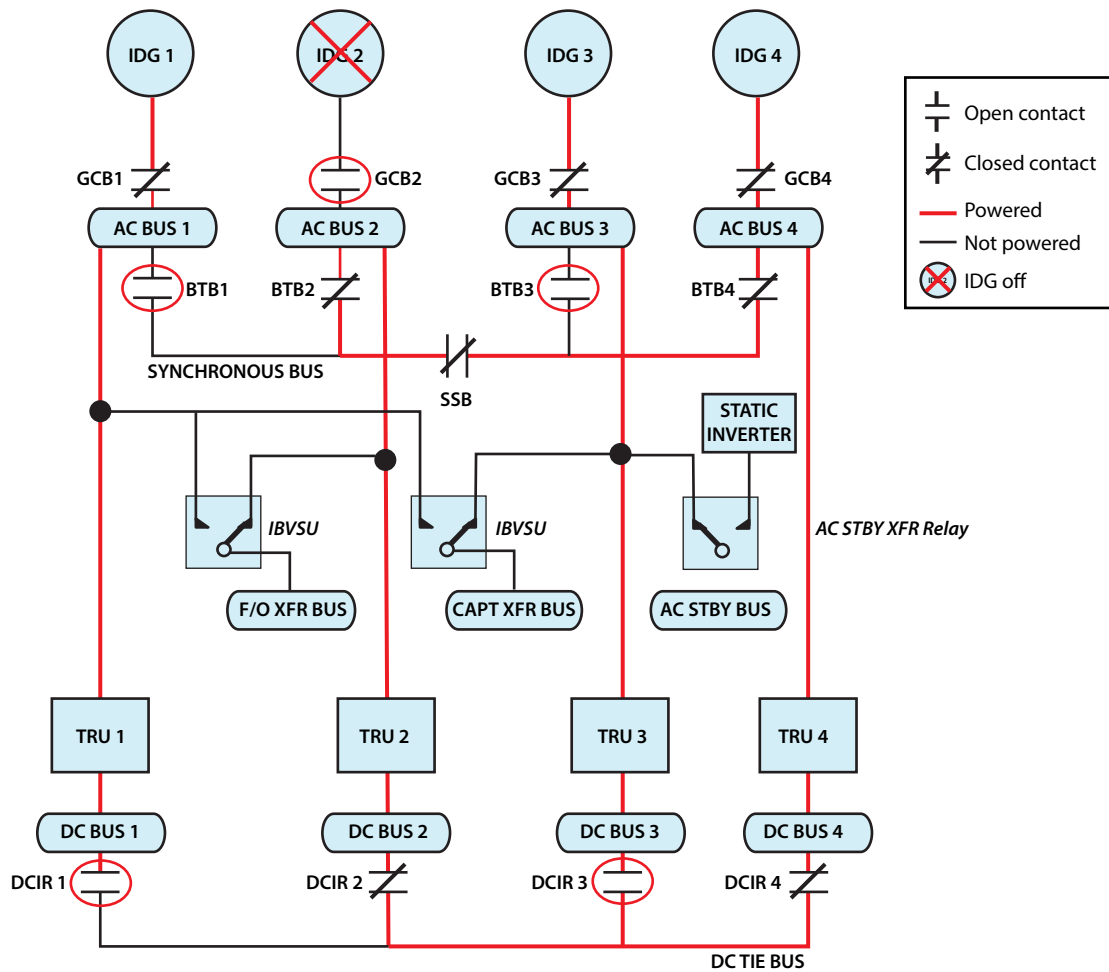

*Adapted from Copyright material
with permission of The Boeing Company*

Figure 7

9M-MPL Electrical System Configuration at commencement of the autoland

The integrated display system

The integrated display system displays information for the flight crew on six liquid crystal Display Units (DUs) in the flight deck and comprises a Primary Flight Display (PFD) and a Navigation Display (ND) in front of each pilot, and two EICAS displays on the central part of the instrument panel (Figure 8).

The PFDs present aircraft attitude, performance, flight path and autopilot mode information. The NDs provide navigation, weather radar and Traffic and Collision Avoidance System (TCAS) information. The upper EICAS screen presents engine primary data, aircraft system configuration information and, following an aircraft system failure, a list of inoperative items and required crew checklist actions. The lower EICAS screen provides synoptic displays showing aircraft system status.



Figure 8

The B747-400 integrated display system

Integrated display system power supplies

Electrical power to the six flight deck displays is provided as follows: the commander's PFD, ND and the upper EICAS screen are powered by the Captain's Transfer Bus, which is normally powered by AC Bus 3 through an Instrument Bus Voltage Sensing Unit (IBVSU). If the primary power source is lost, the IBVSU will automatically switch to AC Bus 1 to power the Captain's Transfer Bus. The first officer's PFD, ND and the lower EICAS screen are powered by the First Officer's Transfer Bus which is normally powered by AC Bus 2 through another IBVSU, with AC Bus 1 as a backup power source (Figure 7).

The IBVSUs continually monitor each phase of primary power. When the voltage of any phase of the primary power drops below 97 ± 2 V for 187 ± 12 ms, the IBVSU will transfer the associated instrument bus to the alternate power source. The IBVSU will transfer the instrument bus back to the primary power source when all three phases of primary power source voltage recover to above 106 ± 2 V for 1.2 ± 0.2 secs. The IBVSU has a 180 ms delay when transferring from a primary to an alternate power source, and not more than 20 ms delay when transferring from an alternate back to the primary source. Auxiliary contacts in each IBVSU are used to provide an indication on EICAS when a flight instrument transfer bus has transferred erroneously, or when one fails to transfer when required.

Cockpit lighting power supply

Many of the cockpit lights, including the lights on the various instrument panels are powered by AC Bus 3.

Timeline

The following timeline was created from the DFDR data and from the Present Legs Faults (PLF) page in the CMC.

Time	Event	Source of information
2144	Engine 2 Shutdown complete	DFDR/ PLF
2301:43	Aircraft captured localiser at 3,200 ft (press alt)	DFDR
2301:55	Centre and Right A/P engaged at 3,040 ft (Left had already been engaged)	DFDR
2302:06	Descending through 3,000ft, momentary power interrupt to AC Bus 2 lasting 1 sample (this discrete is sampled every 4 secs)	DFDR
2302:06	All A/P and A/T disengaged	DFDR
2302	ELEC BUS ISLN 4 - BUS TIE BREAKER 4 TRIPPED 'DIFFERENCE CURRENT' (GCU4)	PLF
	AC BUS 2 NOT POWERED (INTERMITTENT)	
	FIRST OFFICERS AC BUS NOT POWERED (INTERMITTENT)	
	FO XFR BUS – FO TRANSFER RELAY FAIL (BCU)	
	BUS CONTROL UNIT/ FCC-C FAIL (INTERMITTENT)	
	BUS CONTROL UNIT FCC-R FAIL (INTERMITTENT)	
2302:36	Aircraft Captured glideslope at 2,980 ft	DFDR
2305	ELEC BUS ISLN 1 – ADVISORY, BUS TIE BREAKER-1 TRIP 'DIFFERENCE CURRENT' (GCU-1)	PLF
2305:30	AC Bus 2 unpowered	DFDR
2306:03	Aircraft landed	DFDR
2314:34	AC Bus 2 power came back on	DFDR
2314:56	AC Bus 3 power off	DFDR
2314:57	FDR recording stops	DFDR

Detailed aircraft examination

'Autoland Unique' function tests

An 'Autoland Unique Test' can be conducted on the ground via the aircraft's CMC to verify that the correct signals are sent to the BCUs in response to an autoland request from the FCCs. When this test is conducted with the engines running, the electrical system physically reconfigures to provide the autoland isolation configuration. This test was performed a number of times during post-incident troubleshooting, with GCB 2 open to represent the incident configuration. Following completion of each Autoland Unique Test, when the electrical system should have returned to its previous configuration, BTB 3 was observed (on the EICAS electrical system synoptic and on the P6 electrical power control panel) either to remain open or to take a considerable time to re-close (between 30 secs and 2.5 minutes), resulting in AC Bus 3 remaining isolated.

Component testing

Removed components

The following electrical system components were removed for further investigation and subjected to their manufacturer's Acceptance Test Procedures (ATP): IDG 2, GCB 2, First Officer's IBVSU, BTB 3, BCU 1 and GCUs 1 - 4. No anomalies were noted on any of these components during testing, except for BTB 3.

BTB 3 examination

BTB 3 was tested in accordance with the manufacturer's ATP. When voltage was applied to command the BTB to trip, only some of the main and auxiliary contacts transitioned to the expected positions. This resulted in the contactor being in an intermediate state, which did not correspond to either the tripped or the closed condition. When voltage was then applied to command the BTB to close, it did not change state. However when the BTB was subjected to a light external impact on the outer case, the contacts moved and it returned to the closed state. Repeated testing confirmed that it was not possible to predict which contacts would move to the expected positions when the BTB was commanded to trip or close.

After removal of the BTB outer housing, a nut on one of the armature guide posts was found not properly secured, causing the armature to be misaligned (Figure 9). Loctite⁹ was evident on the nut and threads of the guide post, in accordance with the design.

The lock washers on both guide posts had been compressed, as designed, when the nuts were tightened. This suggests either that the nut had backed off over time, perhaps due to airframe vibration, or that the contactor had been disassembled at some point after original assembly. The BTB manufacturer was not aware of any previous cases of the guide post nut loosening in service. The manufacturing drawing did not specify a torque requirement for the nut.

Examination of the main contacts revealed that they exhibited very little wear for a unit of its age (14 years), although there were indications that the contacts had been filed or buffed at some point after manufacture. BTB 3 had been installed on the aircraft since delivery and the component history records indicated that it had never been removed or overhauled.

After tightening the loose nut and replacing the washers, the contactor operated correctly.

Footnote

⁹ A thread-locking compound intended to prevent threaded nuts coming loose.

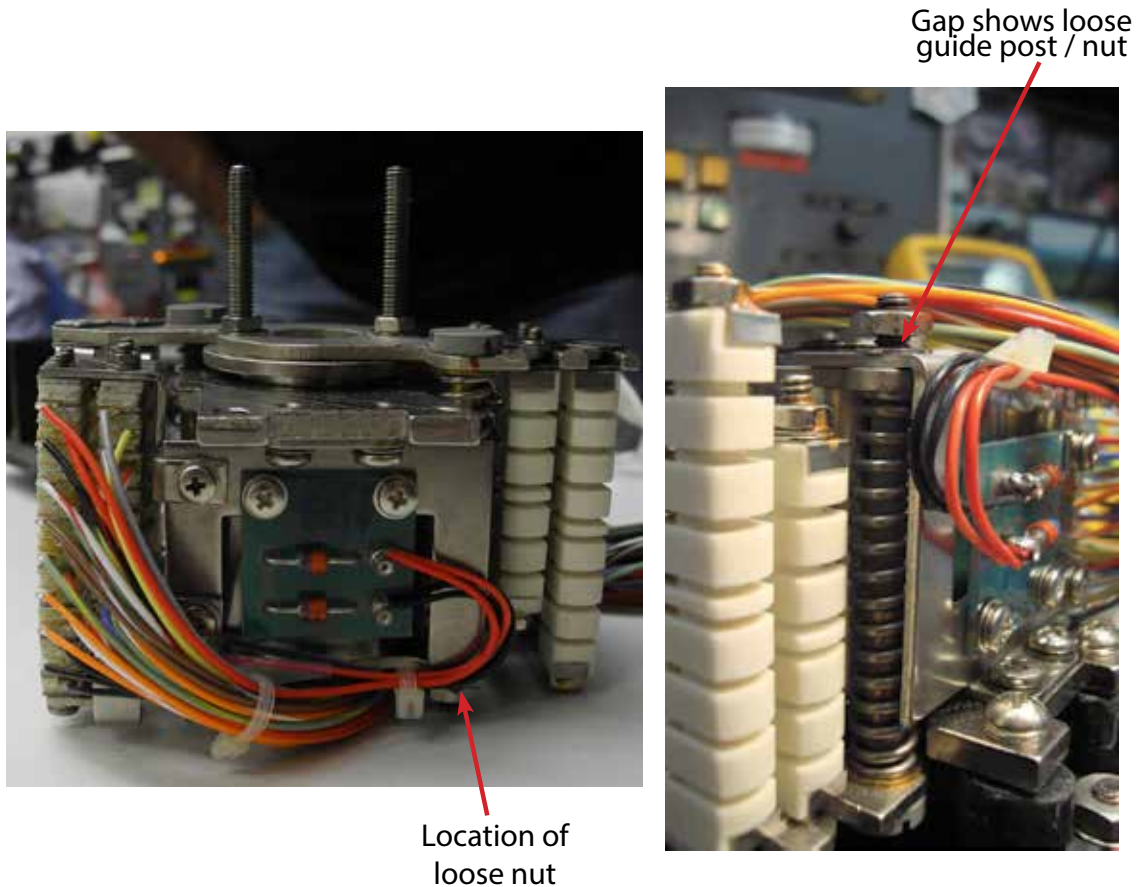

Figure 9
BTB loose guide post nut

B747-400 electrical systems test rig

Preliminary testing

The B747-400 electrical systems test rig at the manufacturer's facility was used to try to recreate the electrical system anomalies observed during the incident. The rig was representative of, but not identical to, the aircraft electrical system. The rig could be instrumented such that voltage and current at various points could be recorded. It was not equipped with flight deck displays.

Testing was initially carried out with shop units installed on the rig, with IDG 2 offline to simulate the No 2 engine shutdown during the incident. Electrical loads typical of the approach phase of flight were applied to each main AC Bus. In this condition, when the electrical system was commanded to reconfigure to the autoland configuration, it configured correctly. However, when the electrical load on either AC Bus 2 or 4 was marginally increased such that the total load on IDG 4 slightly exceeded its nominal 90 kVA capability, BTB 4 tripped after a few seconds due to Difference Current Protection. When the autoland request was removed and BTB 3 was manually tripped to simulate its failure to close during the incident, BTB 1 also tripped due to Difference Current Protection.

A number of other electrical system configurations were trialed to simulate other IDGs being offline. The Difference Current Protection BTB trips were observed to occur any time a single IDG was tied to the sync bus and was carrying the load of more than one AC Bus, even when the electrical system was not in the autoland configuration.

Testing of components from 9M-MPL

Further testing on the electrical system test rig was performed with the following components from the incident aircraft installed in place of the normal shop units: GCU 1, 2, 3 and 4, BCU 1, BTB 3, and the First Officer's IBVSU. GCB 2 from 9M-MPL was not installed due to access difficulties on the test rig.

When first installed on the test rig the incident BTB 3 was noted to be in an intermediate state. The most notable effect of this condition was observed when the test rig was powered by external power, before the IDGs had been brought online, corresponding to an aircraft receiving ground power. In this configuration, all GCBs are usually open and all BTBs are usually closed. The AC Buses receive their power from the sync bus through their BTBs, rather than directly from their respective IDGs. The AC Standby Power Transfer Relay, which is powered directly by AC Bus 3, was observed to energise and de-energise alternately and the AC Standby Bus voltage was observed to fluctuate. In addition a CAPT XFR BUS EICAS message was generated.

The AC Standby Power Transfer Relay is an AC voltage sensing relay that drops out when the Phase C voltage drops to between 88 V and 8 V AC and picks up when the Phase C voltage is greater than 109 +/- 2 V AC. This indicated that the BTB 3 main contact T3 / L3 (Phase C) was neither in the fully closed nor the fully open position, so the voltage across this main contact appeared intermittently and resulted in energising and de-energising the relay.

Repeated testing confirmed that commanding BTB 3 to trip or close could produce random combinations of main and auxiliary contact positions, and thus a variety of effects on the electrical system. When the rig was powered by IDG power, in the incident configuration, Difference Current Protection trips occurred on BTB 4, even when nominal approach electrical loads were applied to AC Bus 2 and 4.

Follow-up testing

Subsequent testing performed by the aircraft manufacturer at a later date, with shop units installed on the test rig, determined that high resistance in the difference current auxiliary contacts 51/52 of the BTBs or GCBs could lead to the GCCT signal on the respective channels not correctly shorting across the auxiliary contacts, and thus cause BTB trips due to difference current. This effect was demonstrated with the test rig in the incident configuration, by artificially increasing the resistance across the difference current auxiliary contacts of GCB 2. Depending on the electrical load on IDG 4, BTB 4 tripped due to Difference Current Protection at resistance values between 2.3 and 5.1 ohms.

This led the aircraft manufacturer and the electrical system supplier to hypothesise that, had there been a build-up of resistance on the auxiliary contacts of the GCB 2 installed

on 9M-MPL, they might not have correctly shorted the GCCT 2 current signal. A false indication of the current being carried by IDG 2 could possibly have accounted for the difference current protection trips during the incident. The resistance on the difference current auxiliary contacts 51-52 of the incident GCB 2 was measured at 0.6 ohms, in the days following the incident. A subsequent resistance measurement at a later stage in the investigation was measured at 0.03 ohms.

The aircraft manufacturer advised that the test rig had not been used for a number of years prior to this investigation. They therefore considered it possible that the initial test results, with normal shop units, could have been influenced by high resistance build-up on the difference current auxiliary contacts of the various BTBs and GCBs installed on the test rig, and that repeated cycling of these contacts during the testing had caused the high resistance to dissipate.

Resistance can build up over time on electrical contacts due to lack of use, poor surface contact, contamination or oxidation. The resulting poor contact can result in poor electrical performance. Repeated exercising of electrical contacts or cleaning can cause contact resistance to dissipate.

Previous Difference Current Protection faults

The aircraft manufacturer conducted a review of the available B747 fault history data for the period December 2000 to August 2012 to search for CMC fault codes associated with DCP BTB trips resulting in AC Bus isolations. This was done for the global B747-400 fleet, for the operator's B747-400 fleet and for 9M-MPL in particular.

There were 4,721 DCP BTB trips resulting in isolation of the associated AC Bus in the database split approximately equally among BTB 1 - 4. For the operator's fleet there were 391 events, 64% (250) of which occurred on BTB 4. 47% (188) of the operator's total events occurred on 9M-MPL, of which 98% were BTB 4 DCP trips.

The electrical system supplier advised that nuisance DCP BTB trips occurred most commonly when a single IDG was paralleled to the sync bus. This configuration could occur during engine start, as IDGs are progressively brought online one at a time; during single-engine taxi operations; or during an autoland, when typically IDG 4 is the only IDG paralleled to the sync bus. Similar behaviour had been observed by the supplier during development of parallel electrical systems on other aircraft.

The data search was further refined to look for BTB DCP trips resulting in AC Bus isolations while the aircraft was in autoland configuration. 26% (1,234) of the 4,721 B747 fleet events occurred during autoland, and 84% (1,036) of these were BTB 4 trips. 44% (175) of the events on the operator's fleet occurred during autoland, almost all of which (99%) were BTB 4 trips and occurred on 9M-MPL.

It was not possible to determine from the data whether any of these combinations of faults occurred with an IDG offline. Data for 9M-MPL indicated that the BTB 4 DCP trips occurred in clusters over periods of a few months at a time and dated back many years.

Aircraft maintenance history

A review of the technical log for 9M-MPL from July 2007 to August 2012 showed many previous occurrences of AC bus isolations. Of particular note was an entry for AC Bus 3 and 4 isolations, during approach on 14 June 2012.

Additionally, there were numerous clusters of AC bus isolation events during approach over periods of a few days in March and April 2011, August 2009, May and June 2009 and October 2007. Some of the events occurred when one IDG was disconnected. Nine of the events involved multiple AC bus isolations. Several of the bus isolations resulted in 'NO LAND 3' EICAS messages, suggesting that planned autolands were cancelled. During some of the periods when these events were prevalent, successful autolands were also recorded in the Technical Log.

No AC bus isolation was recorded, but a defect on 11 December 2011 recorded in the Technical Log stated that when the approach mode was armed the cockpit lights started to flicker until touchdown and a 'F/O XFR BUS' EICAS message was generated. The First Officer's IBVSU was tested and no anomalies were noted.

Detailed engine examination

Engine No 2 was a Pratt & Whitney PW 4056 engine, serial number P729050, with a total operating time of 44,084 hours and 4,775 cycles at the time of the incident. It had accumulated 27,505 hours and 2,857 cycles since the last overhaul.

Preliminary borescope inspections of the engine revealed multiple high pressure turbine (HPT) 2nd stage blade fractures. During disassembly of the engine, it was noted that the HPT 2nd stage Blade Outer Air Seal (BOAS) exhibited significant spalling of the abradable ceramic coating. Additionally two HPT 2nd stage BOAS segments had holes through the gas path surface and the aft corner was missing on another segment. All of the HPT 1st and 2nd stage blades appeared to have encountered heavy blade tip rub, and ten of the HPT 2nd stage blades were fractured. A 145° circumferential arc of the brush seal land on the 1st stage Inner Air Seal (IAS) was also missing.

Further detailed examination of the engine and its components by the engine manufacturer determined that material from the HPT 2nd stage BOAS had liberated and impacted the HPT 2nd stage blades, which initiated the fracture of one of those blades through fatigue. HPT 2nd stage Blade No 33 was identified as the primary blade to have fractured based on the specific features of the fracture surface, which exhibited fatigue in multiple locations, progressing from an impact site on the leading edge of the blade, consistent with a hard body impact. Transferred material on the leading edge was high in zirconium and aluminium, consistent with the composition of the abradable ceramic coating used in the BOAS.

The engine manufacturer advised that spalling of the BOAS was a known issue and that they had introduced a redesigned BOAS for this particular engine installation. The redesign is part of an upgrade package available for PW4000 series engines and includes a thin abradable ceramic, which has been shown to be more spall-resistant than the thick coating on the existing BOAS.

Cockpit voice recorder preservation

The Cockpit Voice Recorder (CVR) installation is designed to record audio information when electrical power is selected on the aircraft, and the CVR that was fitted is designed to preserve at least the last 2 hours of audio information. Flight crew communications were considered important to this investigation and the CVR should have provided further insight. However, the CVR continued to run for a considerable time after the aircraft had arrived safely on stand and all of the audio information relating to the event was lost.

ICAO Annex 6, Part I, 11.6 states:

'An operator shall ensure, to the extent possible, in the event the aeroplane becomes involved in an accident or incident, the preservation of all related flight recorder records and, if necessary, the associated flight recorders, and their retention in safe custody pending their disposition as determined in accordance with Annex 13.'

The applicable requirements for this operator regarding the preservation of flight recordings were contained in the Malaysian Civil Aviation Regulations. The operator's Maintenance Management and Organisation Exposition (MMOE) addressed this topic and contained the following policy/procedure:

- II. REMOVAL OF FLIGHT RECORDERS FOR AIRCRAFT ACCIDENT/ INCIDENT INVESTIGATION AND PREVENTION
1. Example of incident investigation which may warrant a flight recorder removal :-
 - a. Instruction from Department of Civil Aviation.
 - b. Instruction from Senior Manager Quality Assurance.
 - c. Air traffic accident/incident.
 - d. Heavy landing/overweight landing.
 - e. Aircraft overrun runway.
 - f. Aircraft leaving the runway surface.
 2. Flight Recorders shall be removed immediately upon receipt of request and to be quarantined for Quality Assurance Department attention.
 3. Quality Assurance Engineer to follow-up on the removal and ensure Flight Recorders are sent for read-out as soon as possible.
 4. Quality Assurance Engineer is responsible to obtain the read-out/print-out and analyse data with Flight Safety Department (incident) or present data to the investigation committee (for accident).
 5. Quality Assurance Engineer /Flight Safety to recommend for prevention of recurrence (if necessary).
- NOTE : The contents of the Flight Recorders in part or in whole are not to be made available to any person external to the investigation except for the purpose in item 4.

Further reference was also made in the operator's Flight Operations Policy Manual (FOPM) which stated the following:

Flight/Cockpit Voice Recorder Recordings

Following an incident that is subject to mandatory reporting or whenever the Authority so directs, the Company shall preserve the relevant original recordings of a flight recorder (if the aircraft involved is so equipped) for a period of 60 days or for another period as directed by the Authority.

Note: The Company shall, within a reasonable time of being requested to do so by the Authority, produce any recording made by a flight recorder which is available or has been preserved.

If the Commander wants to safeguard stored data in case of a serious incident, an entry should be made in the aircraft Technical Log 'Remove Flight Data Recorder for investigation'.

Cockpit voice recorder recordings may not be used for purposes other than for the investigation of an accident or incident subject to mandatory reporting except with the consent of all crewmembers concerned.

Whenever it is intended to safeguard the CVR data, an entry should be made in the aircraft Technical Log 'Remove Cockpit Voice Recorder for investigation'. (If accessible on the flight deck, the circuit breaker may be pulled to stop the CVR from continuous recording with the aircraft power on.)

The CVR/FDR shall not be switched off, unless essential to preserve accident or serious incident.

The MMOE contains examples of events when flight recorders need to be preserved, but the list is brief and does not cover the circumstances encountered by the crew of 9M-MPL. In the FOPM, no mention is made of the requirement to preserve the recordings following an accident and no obligation is placed on the commander to preserve them in the event of a serious incident. The phraseology used indicates that it is at the commander's discretion to do so.

As the recording duration of a CVR is relatively short (30 minutes or 2 hours) it is essential that the recordings are secured before further assessment of the circumstances is carried out. Any procedure that does not require the crew to preserve the recordings pending any maintenance inspection will not be conducive to timely preservation of this evidence. In addition, the procedures should ensure that, even if the flight crew successfully remove power from the CVR in a timely manner, subsequent maintenance activity does not include the re-application of electrical power to the recorder. One effective way of preserving CVR and DFDR data is to pull and collar the relevant circuit breakers, and physically remove the recorders. Once permission has been granted by the investigating authority, they can then be reinstated.

The operator of this aircraft was advised, at an early stage of the investigation, of the need to have robust procedures in place for flight and ground crew to minimise the risk of losing information on flight recorders. The AAIB provided guidance on this issue and drew the operator's attention to related guidance provided to UK operators published by the UK CAA in Airworthiness Communication (AIRCOM) 2010/10. The AIRCOM made the following recommendations:

'Operators and continuing airworthiness management organisations should ensure that robust procedures are in place and prescribed in the relevant Operations Manuals and Expositions to ensure that CVR/FDR recordings that may assist in the investigation of an accident or incident are appropriately preserved. This should include raising awareness of Flight Crew and Maintenance staff to minimise the possibility of loss of any recorded data on both the CVR and FDR.

When appropriate, the relevant circuit breakers should be pulled and collared/tagged and an entry made in the aircraft technical log to make clear to any airline personnel that an investigation is progressing. Furthermore, confirmation from the investigating authority/operator is required to be obtained before systems are reactivated and power is restored.

Operators who contract their maintenance or ground handling to a third party should ensure that the contracted organisation is made aware of all their relevant procedures.'

Analysis

Failure of engine 2

Examination of the No 2 engine revealed that spalling of the abradable ceramic coating on the HPT 2nd stage BOAS resulted in a portion of the BOAS being released and impacting the HPT 2nd stage blades. This initiated a fatigue fracture in HPT 2nd stage Blade No 33. Subsequent damage from the liberated blade resulted in imbalance of the high speed rotor, leading to the engine vibration and necessitating shutdown of the engine.

Sequence of electrical failures

Following the engine shutdown at 2144 hrs, IDG 2 was no longer able to provide power to the electrical system and GCB 2 was tripped to isolate IDG 2 from the other channels. The electrical system automatically reconfigured to distribute the loads among the remaining three IDGs and continued to operate normally until the aircraft was on approach.

When all three autopilots were engaged to perform an autoland at 2301:55 hrs, the autoland request was sent to the BCUs by the FCCs and the electrical system automatically reconfigured to provide three independent channels for each of the FCCs. This was achieved by BTB 1 and 3 tripping to isolate AC Bus 1 and AC Bus 3; BTB 2 and 4 remained closed so that AC Bus 2 was powered by IDG 4 via the sync bus (Figure 10).

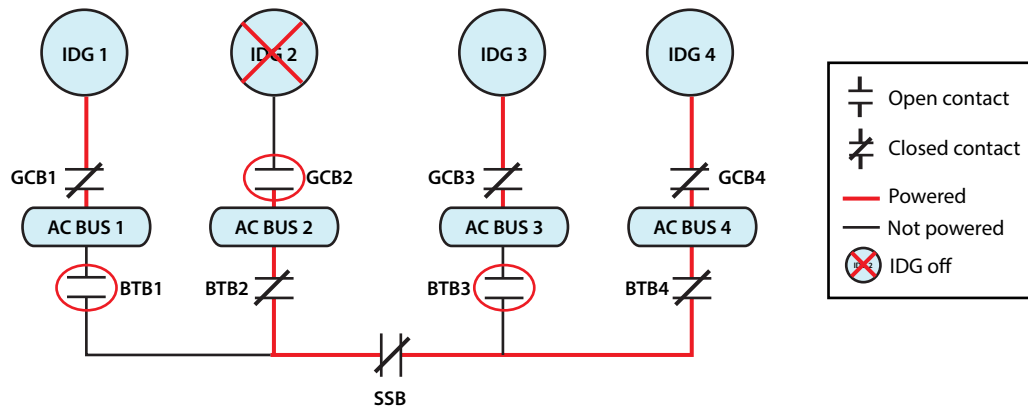

*Adapted from Copyright material,
with permission of The Boeing Company*

Figure 10

Configuration of electrical system at time 2301:55 hrs

Eleven seconds later, BTB 4 tripped because Difference Current Protection isolated AC Bus 4 from the sync bus. Momentary power interruptions to AC Bus 2 and the First Officer's Transfer Bus were recorded. As three independent power supplies could no longer be assured the autoland operation was cancelled, indicated by the 'BUS CONTROL UNIT / FCC-C FAIL' and 'BUS CONTROL UNIT / FCC-L FAIL' faults. BTB 1 and 3 were commanded to return to their previous position and AC Bus 2 then became re-powered (Figure 11).

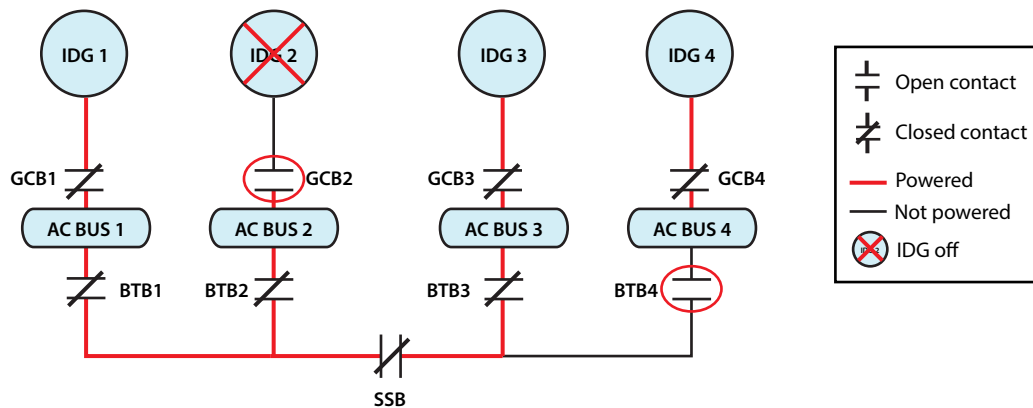

*Adapted from Copyright material,
with permission of The Boeing Company*

Figure 11

Configuration of electrical system at time 2302 hrs

This configuration was sustained for a further three minutes until 2305 hrs, when BTB 1 also tripped due to Difference Current Protection, isolating AC Bus 1. DFDR and CMC data showed that power to AC Bus 2 was lost at this point. AC Bus 2 should still have received power from IDG 3 via BTB 3 but the loss of AC Bus 2 indicates that BTB 3 did

not successfully close and re-parallel to the sync bus when commanded (Figure 12). It is therefore likely that the mechanical failure of BTB 3 prevented some or all of its main contacts from re-closing, leaving it in an intermediate state.

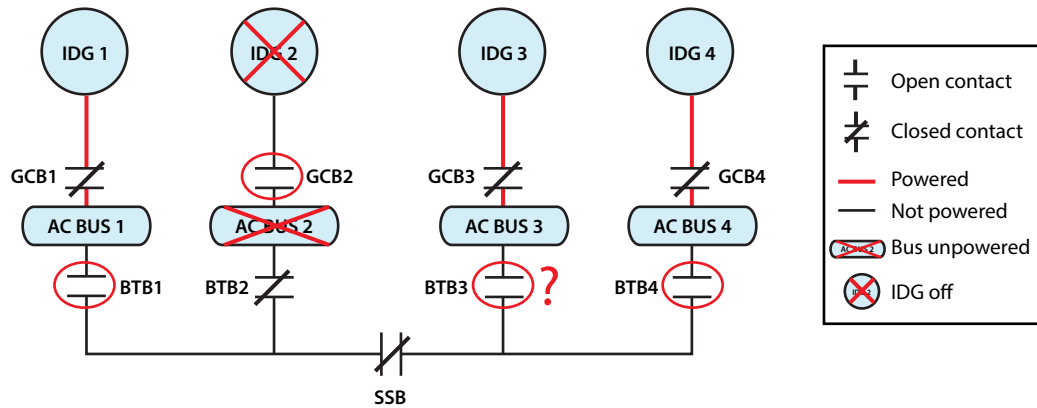

Adapted from Copyright material, with permission of The Boeing Company

Figure 12

Configuration of electrical system at time 2305 hrs

BTB 3 mechanical failure

The loose nut on the BTB 3 guide post allowed the armature to tilt as it moved, causing greater travel on one side than the other. As all of the BTB contacts are transitioned by a single movement of the armature, this defect meant that the correct transition of all of the contacts could not be assured. Tests demonstrated that the BTB could fail in a variety of intermediate states, corresponding to neither the closed nor the tripped state. It was not possible to predict reliably which contacts would correctly transition each time the BTB was commanded to change state. The precise effects on the aircraft electrical system might therefore differ each time the BTB was operated.

Safety action

The manufacturing drawings and component maintenance manual for the B430Z contactors did not include any specific torque requirement for the guide post nuts. As a result of the findings of this investigation, the BTB manufacturer introduced a torque requirement of 18 in/lbs for the guide post nut. Additionally, as this component is installed in the B747-8 aircraft, all newly manufactured B430Z contactors are required to meet enhanced vibration requirements.

Difference current protection trips

The Difference Current Protection of the GCU is designed to protect an IDG from load imbalance when it is operating in parallel with other IDGs. During the incident, two separate BTB trips occurred due to DCP. On each occasion only one IDG was paralleled to the sync bus.

When GCB 2 main contacts tripped after the engine shutdown, the GCB 2 auxiliary contacts would have closed simultaneously to short out the GCCT 2 signal current. Subsequently during the approach when BTB 1 and 3 were commanded to open for autoland, the BTB 1 and 3 auxiliary contacts should have closed to short out GCCT 1 and GCCT 3 signal currents. In this configuration, DCP for channels 1, 2 and 3 would have been effectively disabled. IDG 4 would have been the only generator paralleled to the sync bus and no load sharing would have been taking place with the other generators when the BTB 4 protective trip occurred. The average IDG current output would have been equal to the IDG 4 current output.

True DCP trips can only happen when one or more IDGs are operating in parallel, therefore it is concluded that the BTB 4 trip was a nuisance DCP trip. If the GCCT 1, 2 or 3 current signals had not shorted correctly through the BTB 1, GCB 2 or BTB 3 auxiliary contacts 51/52, GCU 4 sensing circuit would have detected a current imbalance and commanded BTB 4 to trip. For this to happen, at least one set of auxiliary contacts would have had to be open, or have had a contact resistance greater than 1 ohm.

Similarly, when the BTB 1 protective trip occurred, IDG 1 was powering AC Bus 1 and AC Bus 2 which were tied together via the sync bus. As AC Bus 2 subsequently became unpowered, it can be assumed that no load sharing was taking place with IDG 3 at this time. GCU 1 would therefore only have commanded BTB 1 to trip if at least one GCCT was not properly shorted by the BTB 1, GCB 2 or BTB 3 auxiliary contacts.

The particular nature of the mechanical failure within BTB 3 meant that it was quite possible that its difference current auxiliary contacts had remained open, or stuck in an intermediate position during the system reconfigurations. In such a case the GCCT 3 signal may not have been correctly shorted, leading GCU 4 and GCU 1 to detect erroneous difference current signals, and commanding protective trips. It is therefore possible that the BTB 3 fault on its own was sufficient to cause the DCP trips and the subsequent loss of power to AC Bus 2.

However, testing on the electrical systems test rig demonstrated that protective DCP BTB trips could also occur under certain load conditions, and in particular at any time that a single IDG was tied to the sync bus and carrying the load of its own and one other bus. If an IDG is genuinely overloaded, the correct system response is automatic load shedding and not DCP, suggesting that these were nuisance DCP trips. This phenomenon was observed on the test rig even when the defective BTB 3 was not installed. These results were in keeping with the experience of the electrical system supplier. They advised that nuisance DCP trips occurred most commonly during normal operations, when only one IDG was paralleled to the sync bus such as during engine start, single-engine taxi operations or autoland.

After follow-up testing on the electrical systems rig, the aircraft manufacturer and the electrical systems supplier concluded that high contact resistance on the difference current auxiliary contacts of GCB 2 could have led to the DCP trips during the incident. This effect was demonstrated on the test rig by artificially increasing the resistance on the GCB difference current auxiliary contacts and observing the resulting DCP trips. However post-incident

resistance measurements on the GCB 2 from 9M-MPL indicated that the contact resistance was well below the 1 ohm contact resistance limit of the system. This combined with the fact that GCB 2 from 9M-MPL operated normally during ATP testing, and that no testing of this GCB 2 was conducted on the test rig meant it was not possible to verify this theory. Furthermore, as the GCB 2 auxiliary contacts 51/52 closed when the No 2 engine was shut down, high contact resistance, had it existed, could have led to a nuisance DCP at any time, and not just when the electrical system was subsequently commanded to reconfigure for autoland. There was therefore insufficient evidence to identify high contact resistance on the difference current auxiliary contacts of GCB 2 as a specific contributor to the incident. However the possibility of high contact resistance on the auxiliary contacts throughout the difference current loop could not be ruled out as contributing to the sequence of events.

In summary, it was determined that the DCP trips encountered during the incident were not genuine difference current trips resulting from an IDG load imbalance. They were most likely nuisance difference current trips caused by inadequate shorting of the GCCT currents. These could have resulted from the mechanical failure of BTB 3, high resistance on the auxiliary contacts in the difference current loop, or a combination of both conditions.

Previous Difference Current Protection trips

B747-400 fleet fault history reviewed in the course of the investigation indicated that difference current faults are a relatively common occurrence. It was not possible to ascertain from the data how many of these events were due to genuine DCP trips, but the aircraft manufacturer suspected that the high numbers were largely being driven by nuisance trips. Ordinarily, in normal operations, nuisance DCP BTB trips would have a limited effect on the performance of the electrical system. In particular a BTB 4 DCP trip when the electrical system was configured for autoland would have had little or no effect on the electrical system. However, the effect in this case was more pronounced due to one IDG being offline, and IDG 4 having to provide backup power to the affected channel for the autoland configuration.

It was largely possible to correlate the high incidence of BTB 4 DCP trips on 9M-MPL with the defects recorded in the aircraft's Technical Log. This data indicated that the mechanical fault with BTB 3 is likely to have been present and undetected for some time, but was intermittent in nature.

Safety action

As a result of the findings of this investigation, the aircraft manufacturer plans to revise the B747-400 and B747-8 Fault Isolation Manuals (FIM) to include checks of the BTBs, when repeated nuisance difference current BTB trips are recorded by the CMC. The new instructions are planned to be included in the February 2014 revision of the FIMs.

Effects of the electrical failures

It was not possible to reproduce or simulate the flickering of the commander's and first officer's display units during testing in the exact manner described by the crew. However two issues were identified which would have contributed to the displays blanking.

The momentary power interruption to AC Bus 2 following the BTB 4 trip, and the ultimate loss of power on AC Bus 2 resulting from the BTB 1 trip, would have contributed to at least three occasions of momentary blanking on the first officer's displays, as the First Officer's IBVSU switched from AC Bus 2 to the AC Bus 1 alternate power source, and back again. This would not, however, have accounted for any blanking or flickering of the commander's display units.

Testing on the electrical systems rig when the incident BTB 3 was in an intermediate state revealed a condition where one phase of AC power from AC Bus 3 was observed to oscillate, causing intermittent cycling of a voltage sensing relay. Although this precise effect was observed while the test rig was receiving ground power rather than IDG power, the defective BTB could have had a similar effect on the AC Bus 3 voltage during the incident.

As AC Bus 3 is the primary source for the commander's displays, it is quite possible that fluctuating voltage on one or more phases may have caused power oscillations on the Captain's Transfer Bus. However there were no CAPT XFR BUS EICAS messages generated during the incident. This aspect is not fully understood, but one explanation could be that the voltage fluctuations were not sufficiently large, or of sufficient duration to trigger the IBVSU to command the Captain's Transfer Bus to its alternate power source. Fluctuating voltage on AC Bus 3 is also the most likely explanation for the flickering of the cockpit lights, many of which are powered by AC Bus 3. The flight crew reported that flickering of the displays and cockpit lights stopped after landing. It is possible that the firm landing caused some of the BTB 3 contacts to be re-seated. However, it is noted that AC Bus 2 did not become repowered until the aircraft was on the parking standing, most likely coinciding with the application of ground power to the aircraft, which suggests that not all of the BTB 3 contacts transitioned to the closed state.

Loss of AC BUS 2 and its dependent sub-busbars resulted in degradation or loss of multiple aircraft systems, including the right flight control computer. The resultant loss of displayed data, in combination with the flickering displays at a critical phase of flight, created an extremely demanding situation for the flight crew to manage and could have adversely affected the safe operation of the flight.

The simultaneous intermittent blanking of the commander and first officer's displays should not have been possible given that they are powered from independent electrical networks, with alternate power sources in the event of a primary power failure. However, the particular nature of the latent mechanical failure in BTB 3, in combination with the specific configuration of the electrical system, created an unanticipated failure mode.

Given the unique nature of both the event and the BTB 3 failure and the prevalence of nuisance DCP trips during normal operations, other B747-400 and B747-8 operators

should be informed of the details of this incident. The following Safety Recommendation is therefore made:

Safety Recommendation 2014-012

It is recommended that Boeing Commercial Airplanes notify all B747-400 and B747-8 operators of the characteristics of the bus tie breaker mechanical failure on 9M-MPL and nuisance difference current protection trips, emphasising the maintenance actions required if repetitive difference current protection trips occur.

Preservation of flight recordings

The CVR continued to run for some time after the aircraft landed and as a result all relevant CVR recordings were lost. The investigation determined that the operator's procedures for the preservation of flight recordings were not sufficiently robust to ensure that recordings would be preserved in a timely manner following an incident or accident. The operator expressed willingness to address this issue and has proposed amendments to their FOPM. The revised procedures require the commander to secure the recordings as soon as possible after a flight involving a serious incident by pulling and tagging or collaring the appropriate circuit breakers and, if the means for achieving this is not on the flight deck, the commander is required to ensure that the appropriate maintenance personnel take that action. Additional emphasis is also placed on the need to do this before any other maintenance task is conducted.

The operator has circulated these revised procedures as a temporary amendment to the FOPM and intends to provide the associated continuation training. The revised instructions were included in the update of the FOPM issued in July 2013.

The AAIB are satisfied that, when followed, the updated procedures coupled with the associated training will reduce the risk of losing these important flight recordings and, as a consequence, consider that a Safety Recommendation to address this issue is not required.

Conclusion

The intermittent blanking of the flightdeck displays, the complete loss of power to AC Bus 2 and the resultant degradation of multiple aircraft systems were caused by a latent hardware fault on BTB 3, in combination the following factors:

- the failure of No 2 engine, which lead to IDG 2 being offline
- configuration of the electrical system for an autoland
- nuisance difference current protection BTB trips by GCU 1 and 4

The investigation determined that the nuisance difference current protection trips could have been caused by the mechanical failure of BTB 3, high resistance in the difference current loop or a combination of both conditions.